

TRIPLE CONTROL THERMOSTATIC SHOWER VALVE

Shower
control handles
and concealing plate
may differ depending
on Model

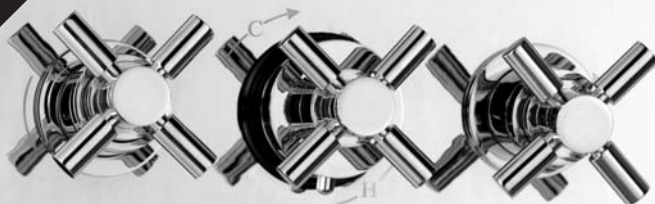

OWNER'S GUIDE

Issue two

These instructions cover all Triple Control Thermostatic Shower Valve Models

INTRODUCTION

This owner's guide shows you how to install, maintain and generally get the most from your triple control thermostatic shower valve.

WE RECOMMEND INSTALLATION BY A QUALIFIED PLUMBER ONLY

TECHNICAL DATA

This shower valve is suitable for use on all common types of plumbing systems including **gravity, pumped, fully modulating combination boilers and high pressure unvented systems.**

Minimum operating pressure 28PSI

Maximum operating pressure 72.5PSI

Important note: At static water pressures above 72.5PSI, you must install a pressure reducing valve in the mains supply pipe set at 43.5PSI static for optimum results.

As a guide to see if your water pressure is too high simply measure how many pints of water you get from your kitchen tap, with the cold side fully turned on. If you exceed 1.2 gallons (or equivalent) in 30 seconds then you require a pressure reducing valve fitting to your incoming mains supply pipe, immediately after the shut-off to premises.

TEST DATA

These valves have been pressure tested to 217.5PSI.

Before proceeding, please note:

1. The valve must be installed in compliance with local water authority byelaws and water supply byelaws.
2. Read all the instruction manual before proceeding.
3. Only begin the installation when you have all the necessary tools ready.
4. Please check that all the components are in the shower valve box.

AFTERCARE

When installing or using tools, extra care must be taken to avoid damaging the finish or the fitting. To maintain the appearance of this fitting, please ensure it is cleaned regularly using a clean soft damp cloth only. Abrasive cleaners or detergents must not be used as they may cause surface deterioration.

TRIPLE THERMOSTATIC SHOWER VALVES

This shower valve uses a wax **thermostatic** cartridge to maintain a constant shower temperature. The valve is **Anti Scald** and will automatically shut down the shower if the cold water supply fails. The valve itself is fitted with three **individual** controls, one to select the showering temperature and two to control the water flow. Once a flow control is turned on, the maximum showering temperature that should be achieved will be a factory pre-set 100°F at override position although this may vary with certain installations. You must ensure that the temperature of your **hot water supply is at least 140°F** for your shower to reach the maximum temperature.

YOUR TRIPLE CONTROL THERMOSTATIC SHOWER VALVE KIT COMPRISES:

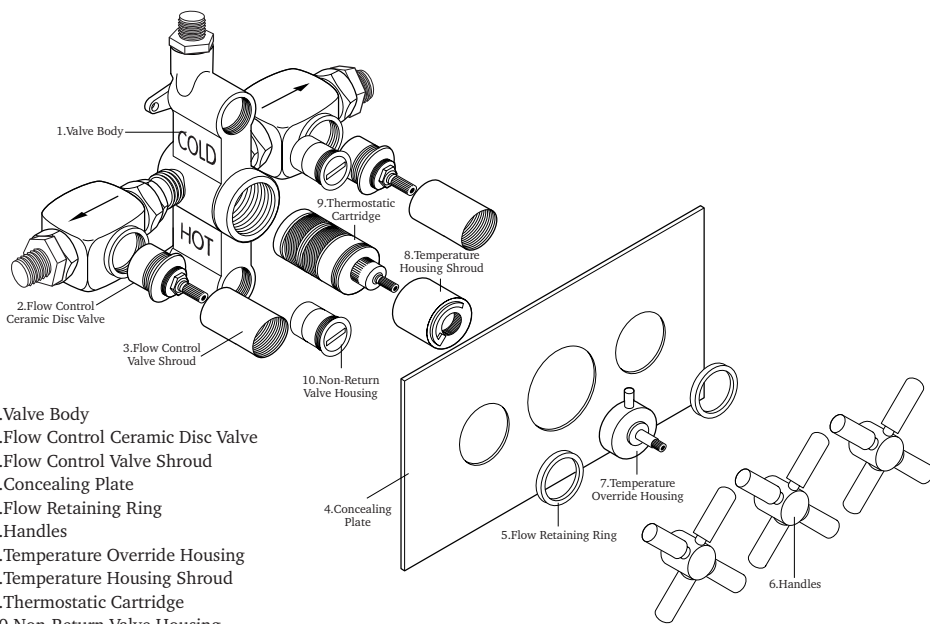

STEP BY STEP INSTALLATION GUIDE

PRE INSTALLATION NOTES

- Identify and check all the parts (**shower control handles and concealing plate styles may differ depending on model**).
- When positioning the valve, ensure you have sufficient pressure for an acceptable shower.
- The hot water feed must **always** be connected to the inlet marked **HOT** of the shower valve.
- Both hot and cold supply feeds must have **accessible isolator valves** fitted in-line for servicing purposes (not supplied).
- Refer to plumbing diagrams for further installation guidelines.
- **Ensure that, after fitting the concealed valve, the area around the valve is left clear and free to allow access for servicing purposes in the future.**

1. PRE INSTALLATION NOTES (continued)

PLUMBING DIAGRAMS

Key to symbols appearing
throughout the Pre
Installation notes:

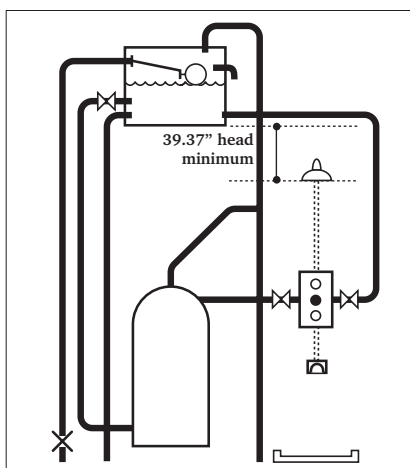
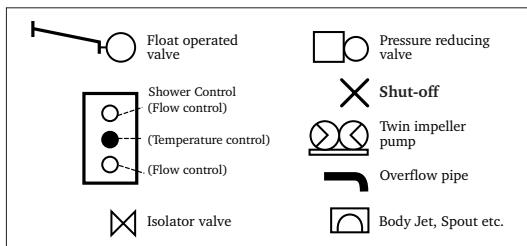

N.B. Wherever possible 0.86" pipework should be used.

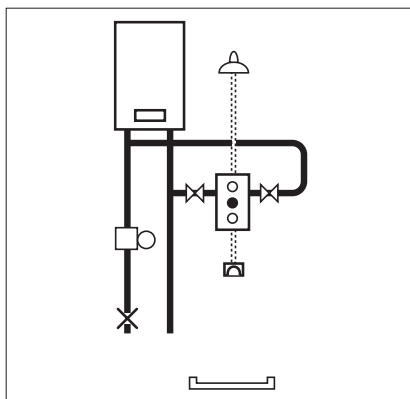

Gravity Fed Showers

The shower valve **must** be fed from a cold water storage tank and a hot water cylinder. The use of a Surrey or Essex flange connection to the hot water cylinder will ensure an independent supply of hot water to the valve; this action will stop air being drawn into the system.

NB Keep all pipework runs as short as possible for maximum shower performance.

Gas Heated/Combi-Boiler Showers

The shower valve **must** be installed with a **modulating** type combi-boiler or multi-point gas heater. This system will produce a constant flow of water within the operating specifications of the appliance. NB The outlet temperature of the system **must** be capable of supplying hot water **in excess of 140°F**.

A pressure reducing valve may be required to ensure that cold water pressures do not exceed 72.5PSI static.

1. PRE INSTALLATION NOTES (continued)

PLUMBING DIAGRAMS (continued)

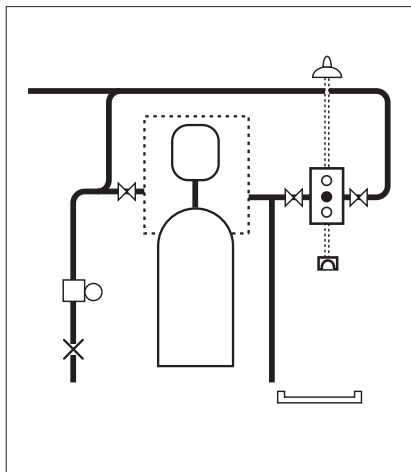

Unvented Mains Pressure Showers

The shower valve can be used on an unvented mains pressure system. This type of system **must** only be installed by **a competent person as per the requirement of Part G of Schedule 1 to the building regulations.**

For systems with no cold water take off after the heaters pressure reducing valve, an additional pressure reducing valve must be fitted, and set, at the same pressure as the heaters.

The water supply pressure to the shower valve must be between 14.5 and 72.5 PSI.

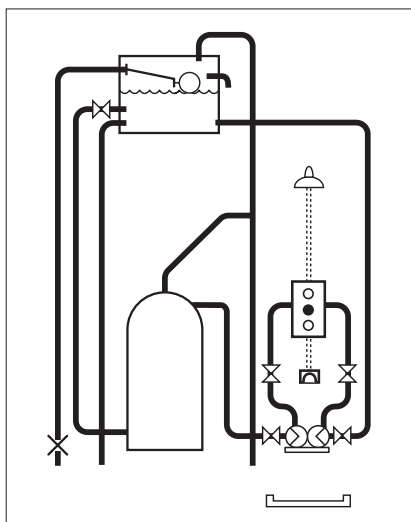

Pumped Showers

The shower valve can be used on a gravity fed pumped system. The use of a Surrey or Essex flange connection to the hot water cylinder will ensure an independent supply of hot water to the valve; this action will stop air being drawn into the system.

NB Please follow pump manufacturers' instructions relating to the siting and water feed details to the pump. Keep all pipework runs as short as possible for maximum shower performance.

N.B. Wherever possible 0.86" pipework should be used to the pump. If non-return valves are fitted to the pump you should remove the ones from the valve inlets to avoid cavitation.

1. INSTALLATION INSTRUCTIONS

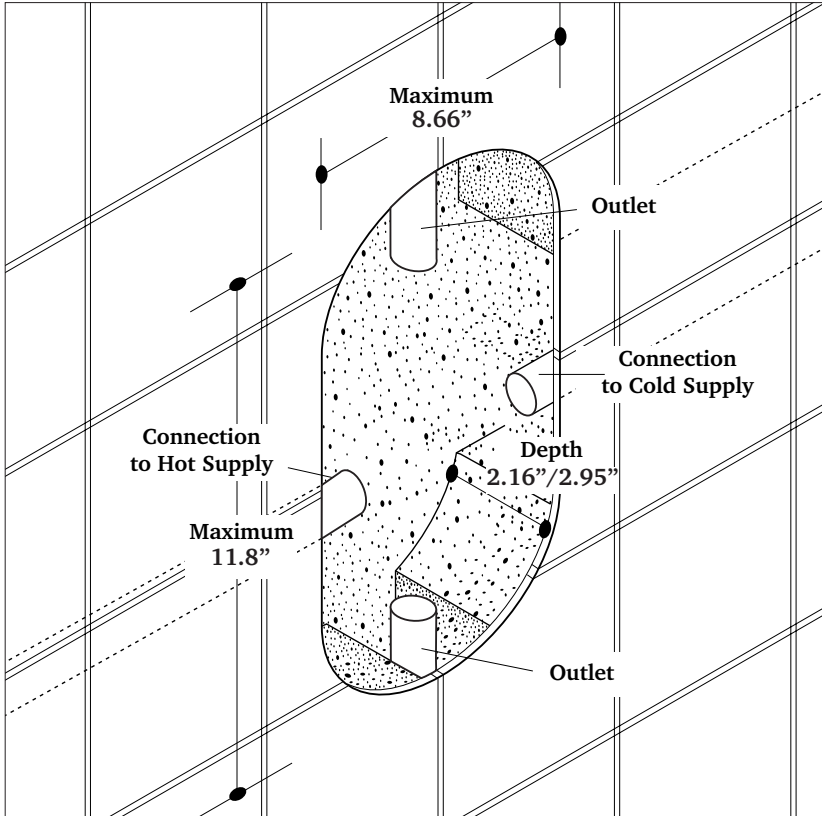

2. SITE PREPARATION

- Make a cavity in the wall to allow the hot and cold water supply and outlet connections to be made.
- Both hot and cold supply feeds must be **flushed through** before connection to the shower valve is made. Re: WRc byelaw 55.
- **Please note: It is permissible to install the valve horizontally. Ensure the hot supply is connected to the inlet marked HOT. Adjust the cavity to suit i.e. 8.66" maximum x 11.8" maximum becomes 11.8" maximum x 8.66" maximum.**

INSTALLATION INSTRUCTIONS (continued)

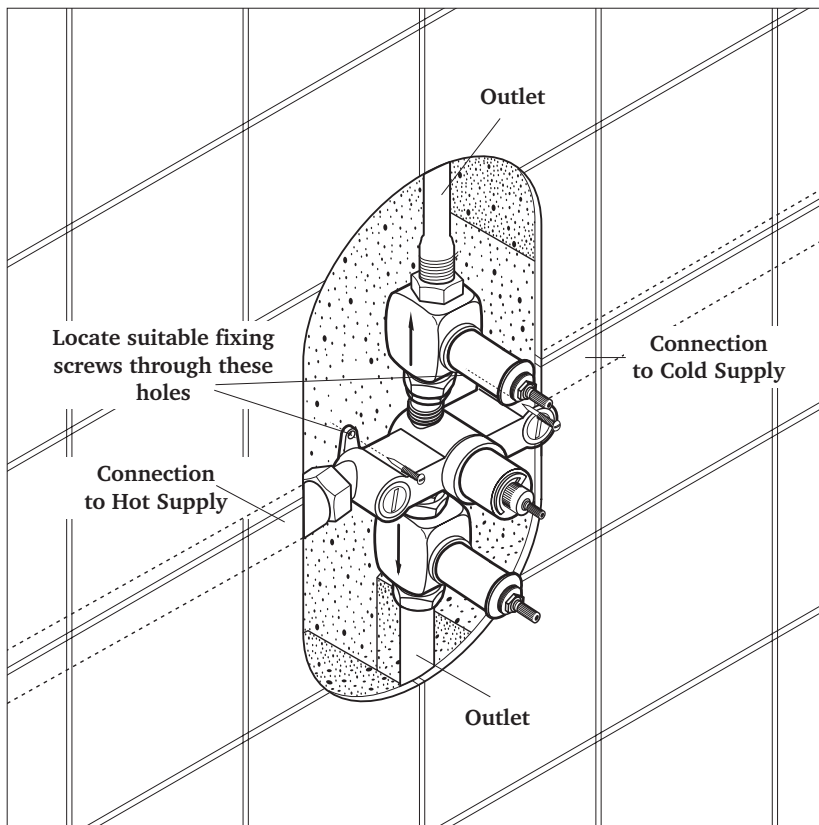
**3. CONNECT TO WATER SUPPLIES**

- Secure the shower thermostatic control main body within the cavity by means of two suitable screw fixings (not supplied).
- Connect the hot and cold water supply feeds to the shower valve, $\frac{1}{2}$ " NPT male inlet.
- Make connection to shower outlets, using the $\frac{1}{2}$ " NPT male iron.
- **CHECK FOR ANY LEAKS.**
- **NB Please ensure that the area around the concealed valve unit is not filled in. Access must be left for servicing purposes.**

INSTALLATION INSTRUCTIONS (continued)

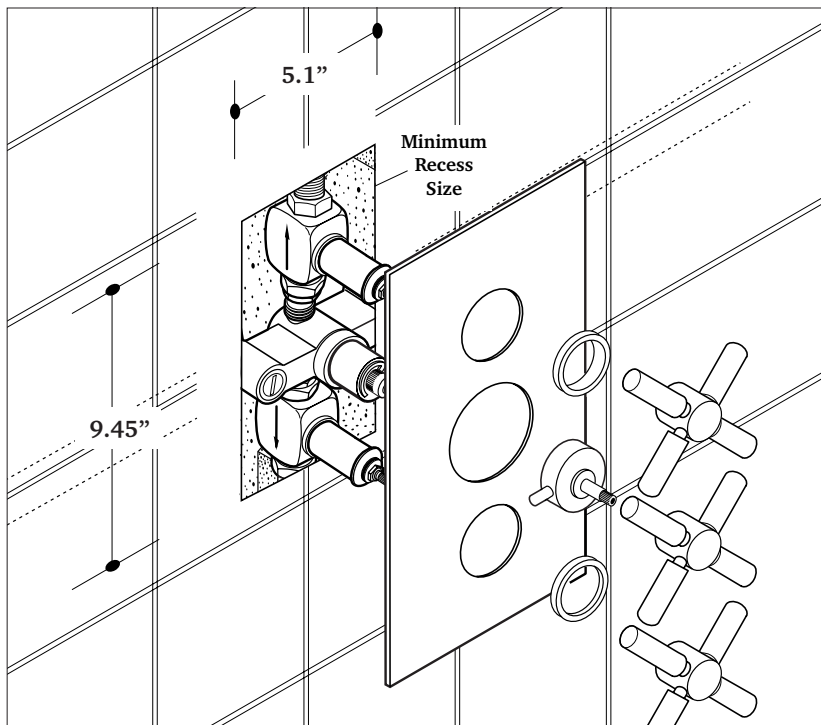
**4. TILE UP/FINISH TO THE MINIMUM RECESS SIZE**

- This will allow for future servicing of the shower valve components.
- **Please note:** If the valve is installed horizontally, the minimum recess size changes from 5.1" x 9.45" to 9.45" x 5.1".

5. FIT CONCEALING PLATE (Plate may differ in style depending on model)

- Remove 'temperature override housing' from thermostatic control. Note: Turn 'override button housing' anti-clockwise until it stops against the preset 100°F stop'.
- Locate concealing plate 'grommet' onto thermostatic control housing and fit concealing plate to valve.
- Carefully refit 'temperature override housing' ensuring that the thermostatic control spindle is not rotated (as this will alter the preset temperature). Note: Ensure that the override button is located against the preset 100°F stop.
- To create a **waterseal**, use a thin line of suitable sealant between the concealing plate and the wall.

INSTALLATION INSTRUCTIONS (continued)

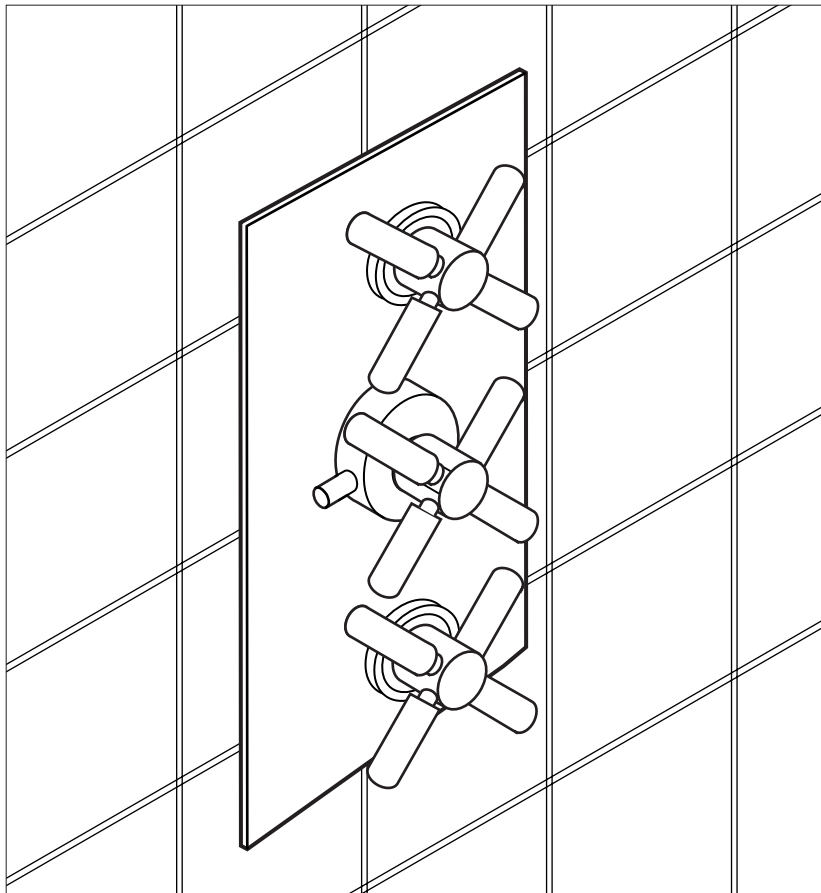
**6. FINAL ASSEMBLY**

- Fit the control handles. (Shower control handles style may differ depending on model).
- Check the function of the valve. The maximum temperature should be 100°F; if not, see Temperature Adjustment.
- Push indices into position (if fitted in handles).

TEMPERATURE ADJUSTMENT

The maximum temperature of the shower valve has been factory pre-set at 100°F at the override position, if for any reason you wish to adjust the maximum temperature, please follow these instructions:

Temperature adjustment - to increase the preset temperature to 38°C at the override position.

1. Set the shower anti-clockwise at the preset 100°F “stop” position
2. Ensure the shower is running
3. Press the override button and turn in small increments anti-clockwise to reach 38°C at the shower outlet rose or handset.

Note: After each increment allow the valve temperature to stabilize for 10 seconds.

4. Carefully remove the handle and ‘temperature override housing’ ensuring that the thermostatic control spindle is not rotated (as this will alter the preset temperature).
5. Carefully refit the temperature override housing and handle ensuring that the thermostatic control spindle is not rotated (as this will alter the preset temperature).

Note: Ensure that the override button is located against the 100°F stop on the temperature housing shroud.

Note: if the shower valve does not adjust to the 100°F minimum, this suggests a problem with the incoming cold supply pressure. Please refer to the ‘Fault Finding Chart’.

Temperature adjustment - to decrease the preset temperature to 100°F at the override position.

- To decrease the temperature carry out the same procedure as above but with a clockwise action.

FAULT FINDING CHART

GRAVITY or PUMPED SYSTEM	
FAULT	DIAGNOSIS
<i>"Showering temperature is not hot enough"</i>	<ul style="list-style-type: none"> • Ensure hot water supply is at least 140°F. • Make sure you have equal pressures. • Check for airlocks in pipework. • Ensure there are no inverted 'U's in any of the pipework runs.
<i>"Water goes cold during shower"</i>	<ul style="list-style-type: none"> • Insufficient hot water storage
<i>"When shower is set at cold, the showering temperature is too hot"</i>	<ul style="list-style-type: none"> • Hot and cold supply connections have been made in reverse - reconnect correctly
<i>"Shower temperature is too hot (pumped shower)"</i>	<ul style="list-style-type: none"> • Turn down the flow of hot water from the pump using the in-line isolator valve.

COMBI or OTHER HIGH PRESSURE SYSTEM	
FAULT	DIAGNOSIS
<i>"Showering temperature is not hot enough"</i>	<ul style="list-style-type: none"> • Incoming mains pressure exceeds 72.5PSI - ensure you have fitted a pressure reducing valve in the mains supply pipe. • Ensure hot water supply is at least 140°F.
<i>"Valve is very noisy when in use"</i>	<ul style="list-style-type: none"> • Incoming mains pressure exceeds 72.5PSI - ensure you have fitted a pressure reducing valve in the mains supply pipe immediately after shut-off to premises.
<i>"The water goes cold whilst showering"</i>	<ul style="list-style-type: none"> • Ensure the boiler is still firing. Adjust the boiler to the hottest output, not the best flow.
<p>NB Any product guarantees will be invalidated if the internal workings of the valve have been tampered with in anyway. <i>Please call our HELPLINE if you are having any difficulties.</i></p>	

**If the Fault Finding chart does not remedy the problem,
 please contact the helpline immediately.
 Telephone +44 (0)1282 446789.**